

| BILL OF MATERIAL | | | | | |
|------------------|-----------|------|-------------------------------|----------|----------|
| SYM. | PART NO. | REQ. | DESCRIPTION | MATERIAL | WT. LBS. |
| 1 | 100901-09 | 1 | STANCHION , HANDBRAKE , LEFT | A-36 | 11.4 |
| 2 | 100901-10 | 1 | STANCHION , HANDBRAKE , RIGHT | A-36 | 11.4 |
| 3 | 96033-01 | 1 | BELLCRANK S/A | A-36 | 47.4 |
| 4 | 100126-59 | 1 | PIPE CUT-TO-LENGTH | A-53 | 2.18 |

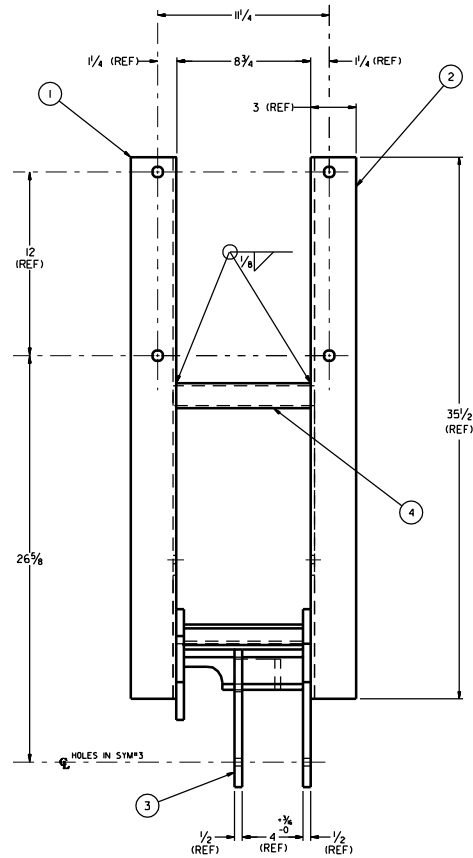
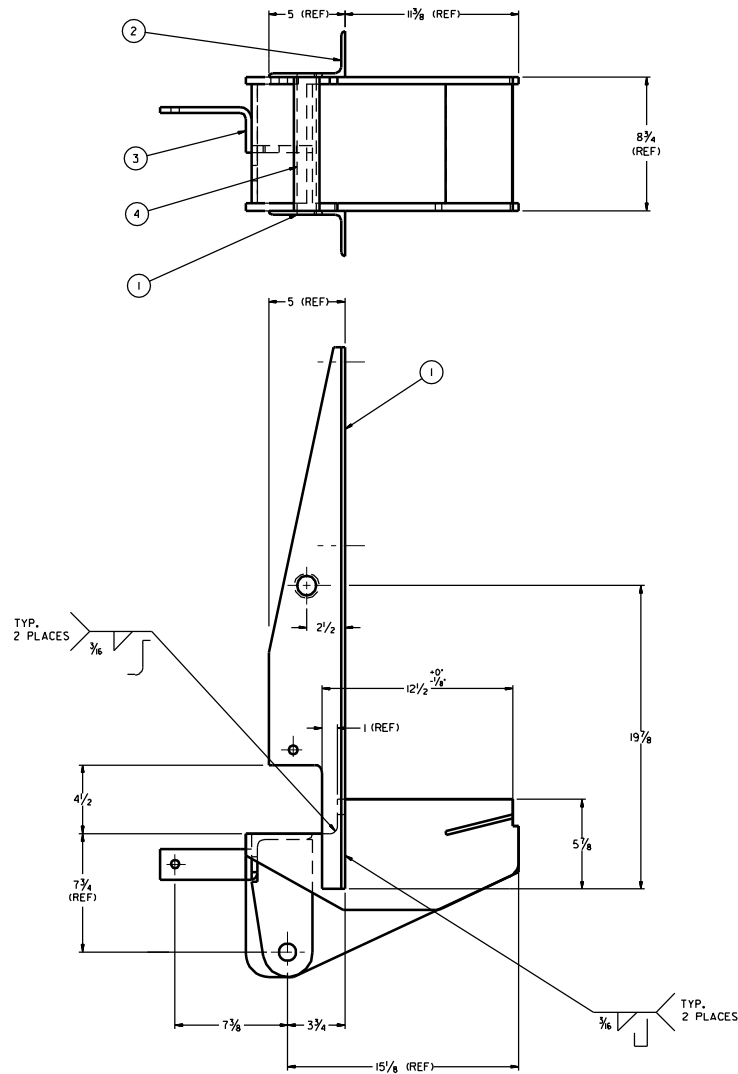

| DEFAULT TOLERANCES - S/A DRAWING | |
|--------------------------------------------------|--|
| ALL DIMENSIONS ARE INCHES UNLESS OTHERWISE NOTED | |
| FRACTIONAL DIMENSIONS: ± 1/16 | |
| ANGULAR DIMENSIONS: ± 1° | |

| REV | DATE | BY | DESCRIPTION | CHK |
|-----|------|----|-------------|-----|
| | | | | |

THIS PRINT INCLUDING ALL INFORMATION SET FORTH THEREON IS PROVIDED IN CONFIDENCE AND WITH THE UNDERSTANDING THAT NO COPIES OF THIS PRINT OR OF THE INFORMATION SHALL BE MADE WITHOUT THE PRIOR WRITTEN CONSENT OF PROCTOR LIMITED. ALL RIGHTS TO DESIGN AND INVENTION ARE RESERVED.

PROCTOR
PROCTOR LIMITED
 200 SPERRY BL.
 WASHINGTON, D.C. 20036

**STANCHION & BELLCRANK
 S/A, CONV. BRAKES w/
 GROUP "N" HANDBRAKE**

DRAWN BY: JAHK, RD, D, T046502 DATE: 03-25-70
 CHECKED BY: W-SATU, R-MAGO DATE: 04-05-70
 APPROVED: R.L. BREZNIK DATE: 04-02-70

SCALE: 1" = 1"-00"
 WEIGHT: 72.4*

DRAWING NO. **96032**

REVISION