

| LINE | SYM#2 PART NO. | SYM#3 PART NO. | WT. LBS. |
|------|-------------------|-------------------|-------------|
| 01 | 103373-01 | 103373-02 | 164 |
| 02 | 103373-03 | 103373-04 | 170 |

| BILL OF MATERIAL | | | | | |
|------------------|----------|------|------------------------------------|----------|------------|
| SYM. | PART NO. | REQ. | DESCRIPTION | MATERIAL | WT. (LBS.) |
| 1 | 95725-01 | 1 | GRATING BOX S/A | SEE S/A | 109 |
| 2 | TABLED | 1 | ANGLE EQUAL LEGS W/2 HOLES ONE LEG | A-36 | --- |
| 3 | TABLED | 1 | ANGLE EQUAL LEGS W/2 HOLES ONE LEG | A-36 | --- |

"A"

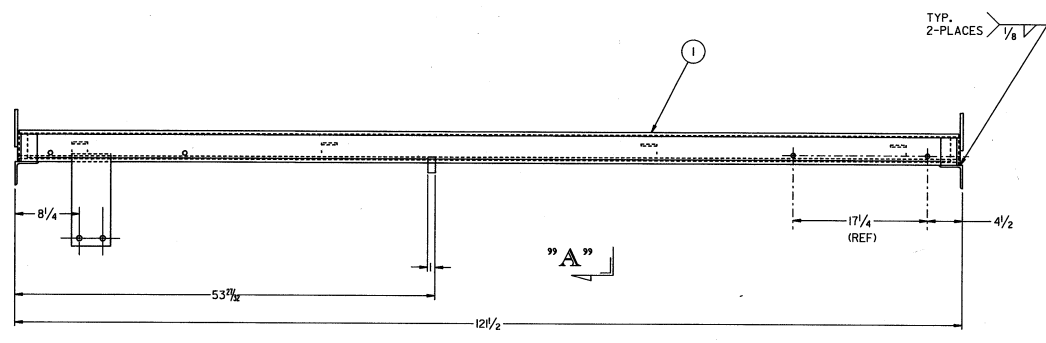

"A"

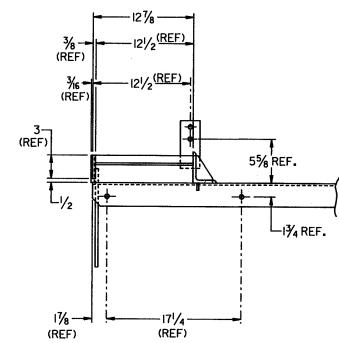

SECTION "A-A"

THIS PRINT, INCLUDING ALL INFORMATION SET FORTH THEREON, IS PROVIDED IN CONFIDENCE AND WITH THE UNDERSTANDING THAT NO COPIES OF THIS PRINT OR OF THE INFORMATION SHOWN HEREON SHALL BE MADE WITHOUT THE PRIOR WRITTEN CONSENT OF PROCOR LIMITED. ALL RIGHTS TO DESIGN AND INVENTION ARE RESERVED.

| | |
|--|--|
| DEFAULT TOLERANCES - S/A DRAWING | |
| ALL DIMENSIONS ARE INCHES UNLESS OTHERWISE NOTED | |
| FRACTIONAL DIMENSIONS: ± 1/16 | |
| ANGULAR DIMENSIONS: ± 1° | |

| | | | | | | | |
|--|------|----|-------------|-----|-------|-------------|----------|
| REV | DATE | BY | DESCRIPTION | CHK | SCALE | DRAWING NO. | REVISION |
| | | | | | | | |
| THIS DRAWING IS THE SOLE PROPERTY OF PROCOR LIMITED. IT IS NOT TO BE REPRODUCED OR COPIED OR DISSEMINATED TO OTHERS. | | | | | | | |

PROCOR
PROCOR LIMITED
 2000 SPENCER RD.
 MISSISSAUGA, ONTARIO
 L4X 1S2

"A" END SILL S/A
121" WIDE, 1" GRATING

DRAWN BY: M. GATIS DATE: 06/27/92
 CHECKED BY: M. GATIS DATE: 06/27/92
 APPROVED: R. BRONZINO DATE: 06/25/92

REV: A DATE: 06.24.93 BY: DesK DESCRIPTION: OVERHANGING TABLE DELETED.
 SCALE: 1/2"=1'-0" DRAWING NO.: 95723 REVISION: A