

LINE	"A"	"B"	"C"	"D"	"E"	"F"	"G"	"H"	"J"	"K"	"L"	WT.(LBS.)	REMARKS
01	7/16	9 3/32	19 3/32	21 1/32	36 3/32	---	21/16	7/8	3 3/32	21/8	57 1/16	84.87	
02	5 3/4	8 5/16	17 1/16	19 5/8	34 3/4	1/4	19 5/16	5 1/16	2 5/16	19 3/16	54	79.5	111 1/8" x 114" O.D. TANK, 90° FROM BOLSTER, 1/4" F.F.
03	8 1/4	10 3/4	20 1/8	22 1/8	37 1/4	---	21 3/4	7 1/16	4 3/16	21 1/8	58 1/2	87.1	
04	5 5/8	8 3/16	17 3/16	19 1/2	34 5/8	1/4	19 3/16	5 5/16	2 1/8	19 3/16	53 1/4	78.76	
05	7 1/16	9 5/8	19	20 5/16	36 1/16	1/8	20 11/16	6 3/4	3 3/16	20 3/4	56 1/4	83.5	
06	5 5/8	8 3/16	17 3/16	19 1/2	34 5/8	1/4	19 1/2	5 5/16	2 1/8	19 3/16	53 1/2	78.88	
07	8 3/16	11	20 3/8	22 3/8	37 5/8	---	21 7/8	8 3/8	4 5/16	21 5/16	59 1/16	87.59	STRAIGHT SHELL CAR
08	8 1/4	10 13/16	20 3/16	22 1/8	37 3/8	---	21 5/16	7 5/16	4 3/16	21 5/16	58 3/4	87.3	
09	7 1/4	9 13/16	19 3/16	21 1/8	36 1/4	---	20 5/8	6 5/16	3 5/32	20 3/32	56 3/8	83.8	
10	7 3/16	9 3/4	19 3/8	21 1/16	36 3/16	1/8	20 13/16	6 1/16	3 5/8	20 7/8	56 1/16	83.44	
11	8 1/8	10 1/16	20 1/16	22	37 1/4	---	21 5/8	7 1/16	4 1/8	21 1/16	58 1/2	86.5	
12	4 7/16	6 3/8	16 1/4	18 1/4	33 3/8	1/4	18 5/16	4 1/8	2 3/16	18 3/32	50 9/16	74.5	
13	5 1/2	8 1/16	17 3/16	19 1/16	34 5/8	1/4	19 3/8	5 3/16	2 3/4	19 3/16	53 3/16	78.82	105 3/4" O.D. TANK, 102" FROM BOLSTER, 1/4" F.F.
14	5 5/16	7 7/8	17 1/4	19 1/4	34 3/16	1/4	19 3/16	4 3/16	2 1/4	19 1/8	53 1/16	78.25	
15	5 5/16	8 1/8	17 1/2	19 1/2	34 3/4	1/4	19 5/8	5 3/16	2 5/16	19 5/16	54 3/16	80.23	118 3/4" OR 98 1/8" O.D. TANK, 90° FROM BOLSTER, 1/4" F.F.
16	8 1/16	11 1/8	20 1/2	22 1/2	37 3/4	---	22	8 3/8	4 3/8	22 1/8	59 5/16	88.3	120" O.D. TANK, 90° FROM BOLSTER, STR. SHELL

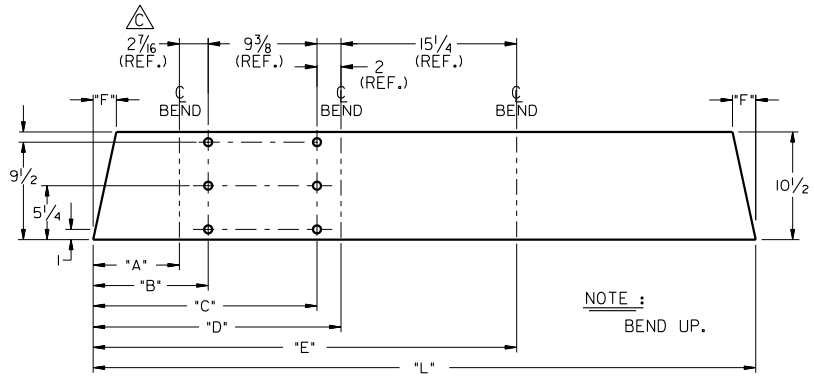
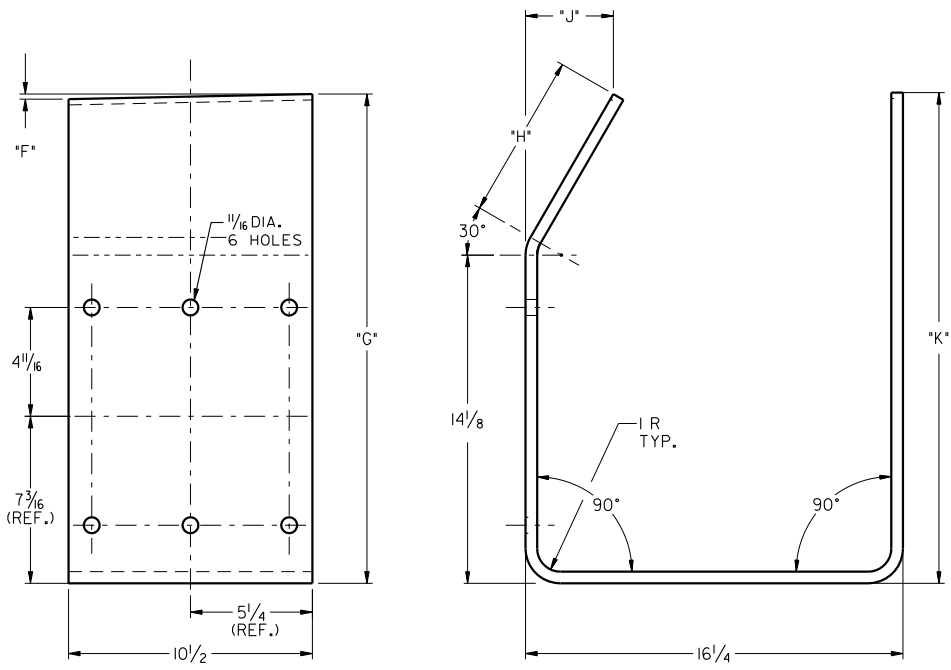

DEVELOPMENT

SCALE = 1:2

MATERIAL: 1/2 x 10 1/2 x "L" LG.  
ASTM A36

**PROCOR** PROCOR LIMITED  
RAIL CAR DIVISION  
300 SPEEDS RD.  
ORAVILLE, ONTARIO  
L6J 9E1

SUPPORT  
BRAKE CYLINDER

C	T.C.	01.05.00	DIM'S. ON LINE *07 REVISED. AND DIM. 2 7/16" WAS 2 3/16"	R.M.
B	RM	05.15.98	REDRAWN - WAS "B" SIZE DWG.	PY
A	MG	06.23.97	SYM.* II "C" DIM WAS 20 3/16"	MG
REV.	BY	DATE	DESCRIPTION	CHK.

DRAWN BY: DesK DATE: 05/18/93  
CHECKED BY: B. McQUEE DATE: 05/19/93

DEFAULT TOLERANCES - S/A DRAWING  
ALL DIMENSIONS ARE INCHES UNLESS OTHERWISE SPECIFIED  
FRACTION DIMENSIONS: ± 1/8  
ANGULAR DIMENSIONS: ± 1°

ORIGINAL WHEN STAMP IS RED

THIS PRINT, INCLUDING ALL INFORMATION SET FORTH THEREON, IS PROVIDED IN CONFIDENCE AND WITH THE UNDERSTANDING THAT NO COPIES OF THIS PRINT OR OF THE INFORMATION SHALL BE MADE WITHOUT THE PRIOR WRITTEN CONSENT OF PROCOR LIMITED. ALL RIGHTS TO DESIGN AND INVENTION ARE RESERVED.

SCALE: 3" = 1'-0"  
WEIGHT: TABLED  
DRAWING NO. 103639  
REVISION C