

NOTE:
BREAK ALL SHARP CORNERS.

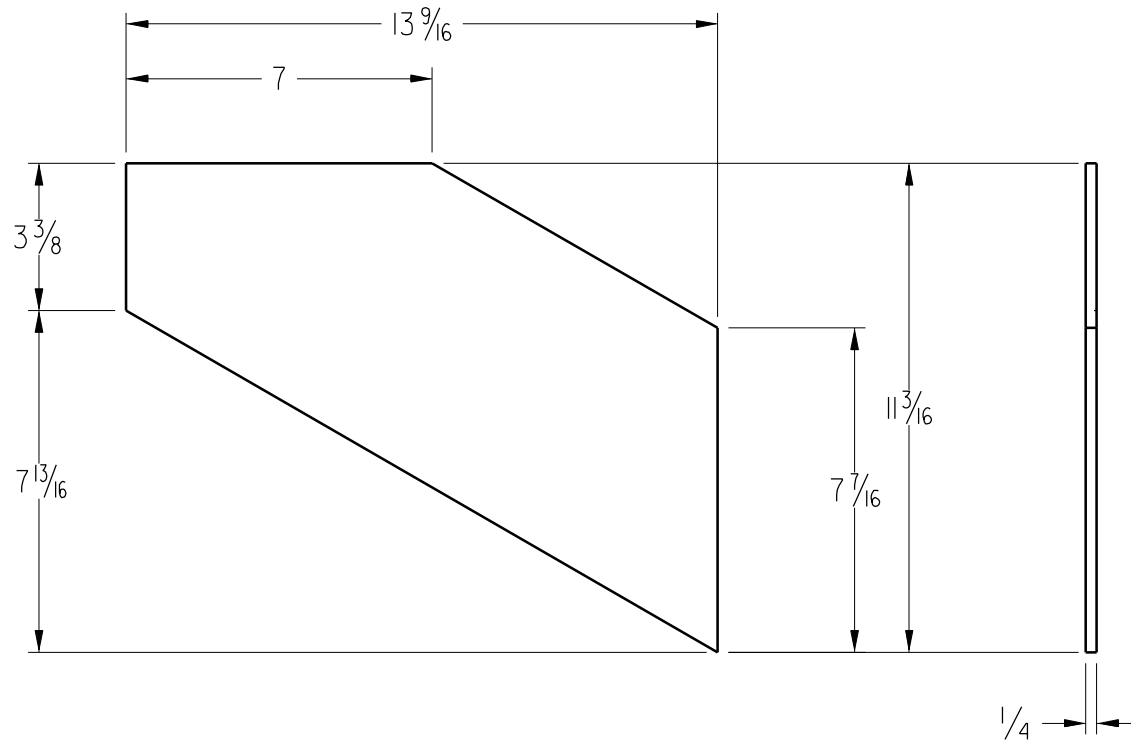

MATERIAL:
1/4 x 11 3/16 x 13 9/16 LG.
STEEL
ASTM A283, GR.B OR A36

THIS DRAWING IS THE SOLE PROPERTY OF UNION TANK CAR COMPANY AND IS LOANED SOLELY FOR UTC PURPOSES.
IT IS NOT TO BE REPRODUCED OR COPIED OR DISSEMINATED TO OTHERS.

REVISION	A	B
DATE	5-28-92	12-10-92
DRAWN	RAL	Desk
ECO NO.	6890-A	---
CHECKED	BP	BFB
MFG ENGRG	N/A	N/A
PRODUCT ENGRG	PCA	---

MAT'L WAS 1/2 A516-70
WT. 11.50#.

MATERIAL REVISION FOR
PROCOR.

<p>DEFAULT TOLERANCES — DETAIL DRAWING</p> <p>ALL DIMENSIONS ARE INCHES UNLESS OTHERWISE NOTED</p> <p>FRACTIONAL DIMENSIONS: ± 1/16</p> <p>ANGULAR DIMENSIONS: ± 1°</p>
--



UNION TANK CAR CO.

151ST & RAILROAD AVE.
EAST CHICAGO, INDIANA 46312

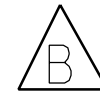

LATEST REVISION

RECTANGULAR SHAPE
WITH CORNERS CHAMFERED

DRAWN BY	DATE	SCALE	WEIGHT	CHECKED
TS	12 MAY92	3 = 12	6.19#	BP
N/A WELDING	N/A MFG.	PCA PRODUCT	102991	
ENGINEERING APPROVALS			DRAWING NO.	

FIRST USED WITH: 95390 REPRO OF: ~~~~~ SEQUENCE NO. 4980