

6	2U233302	2-U-2333-02	PAD-JACKET REINFORCEMENT	1
4	2U307301	2-U-3073-01	SUPPORT-HANDRAIL SIDE	2
6	2U233500	2-U-2335-00	CLAMP-1 1/4 IN. PIPE	3
2	90012258		COUPLING-STEEL 1 1/4	4
2	3U369308	3-U-3693-08	HANDRAIL-SIDE	5
2	3U369402	3-U-3694-02	HANDRAIL-SIDE	6
2	2U307200	2-U-3072-00	SUPPORT-HANDRAIL SIDE	7

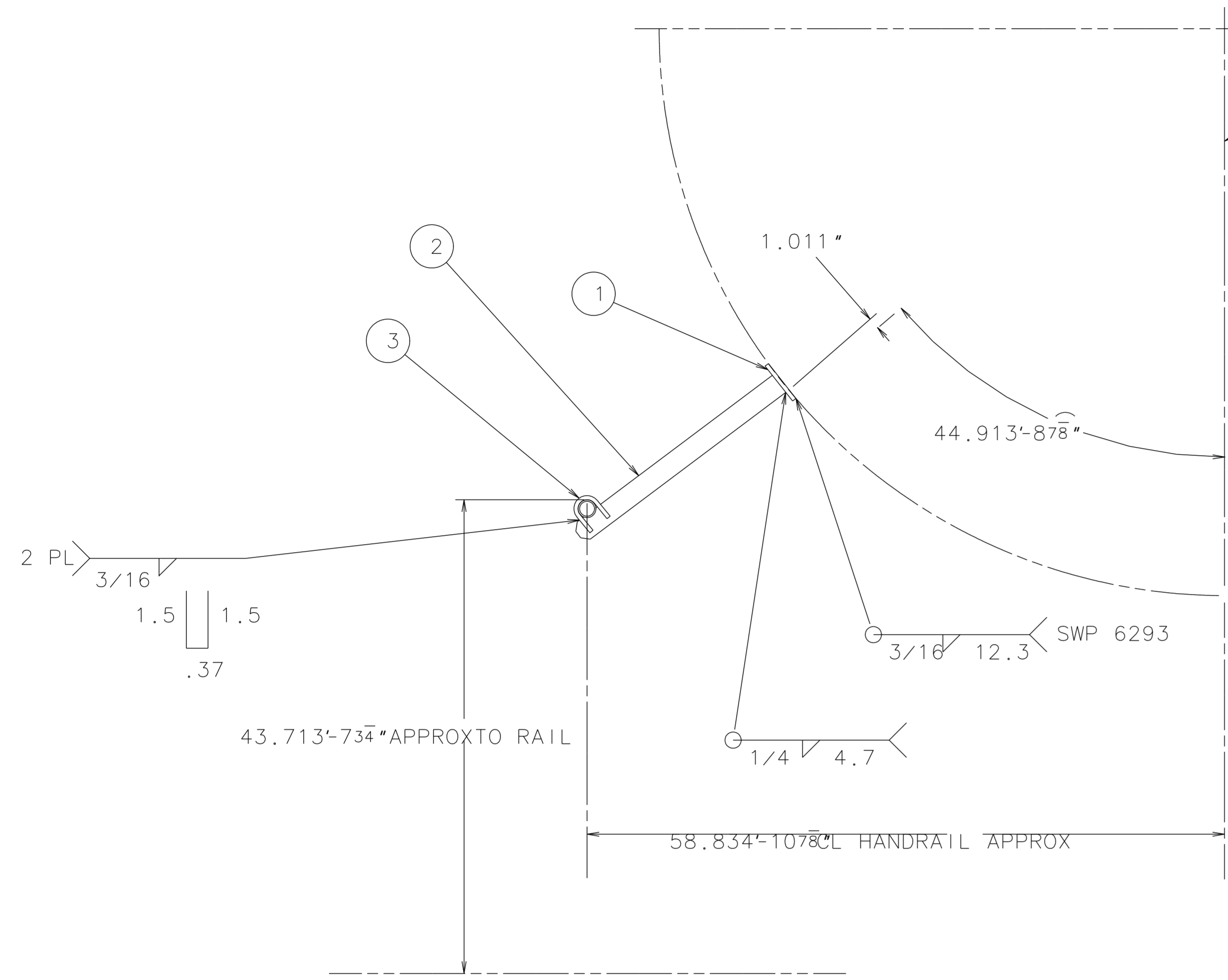

**SECTION A-A**  
SCALE: 1/8  
4 PL

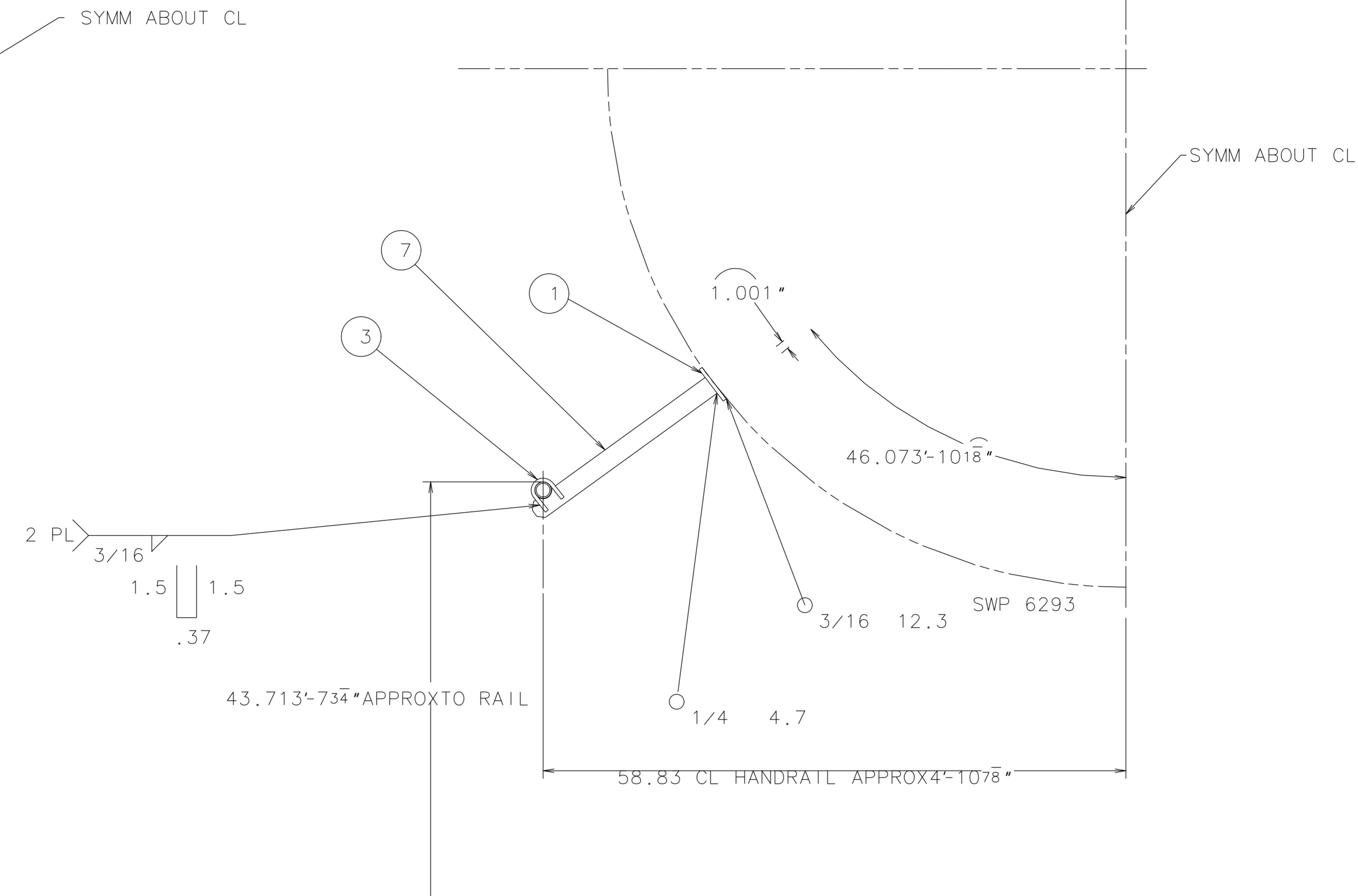

**SECTION D-D**  
SCALE: 1/8  
2 PL

**NOTES:**

1. ALL LOCATION DIM FOR PADS AND SUPPORTS ARE MEASURED ON OUTSIDE OF JACKET.
2. WELD HANDRAIL AT "A" END ONLY, BOTH SIDES.

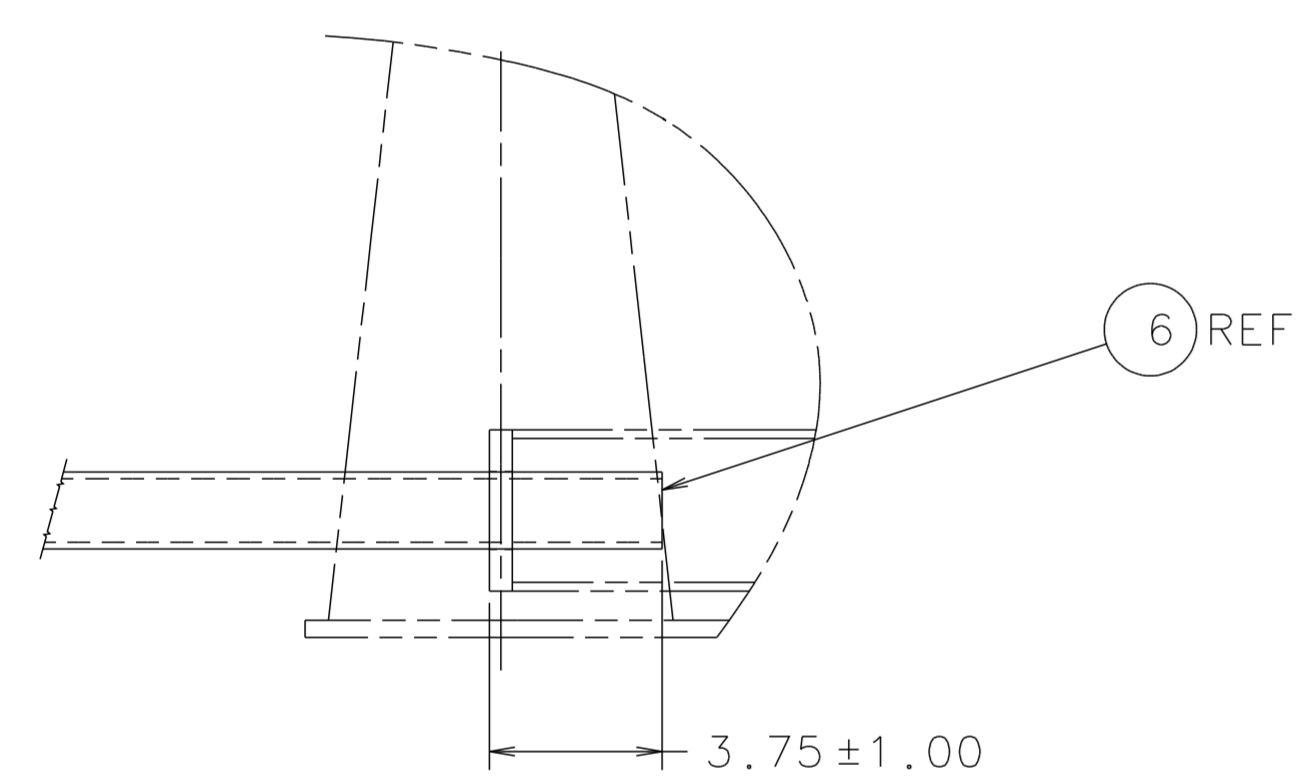

**VIEW C**  
SCALE: 1/4

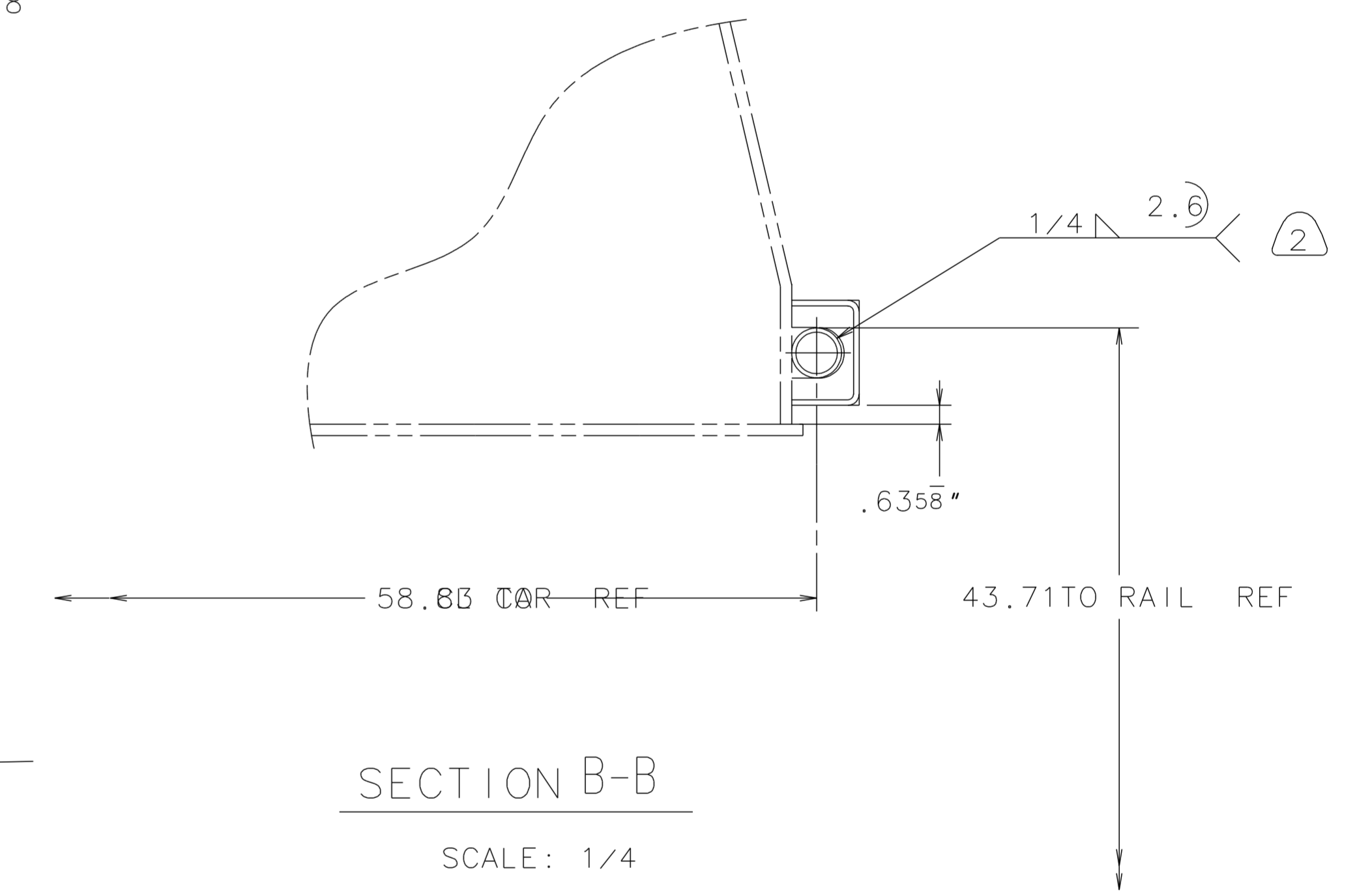
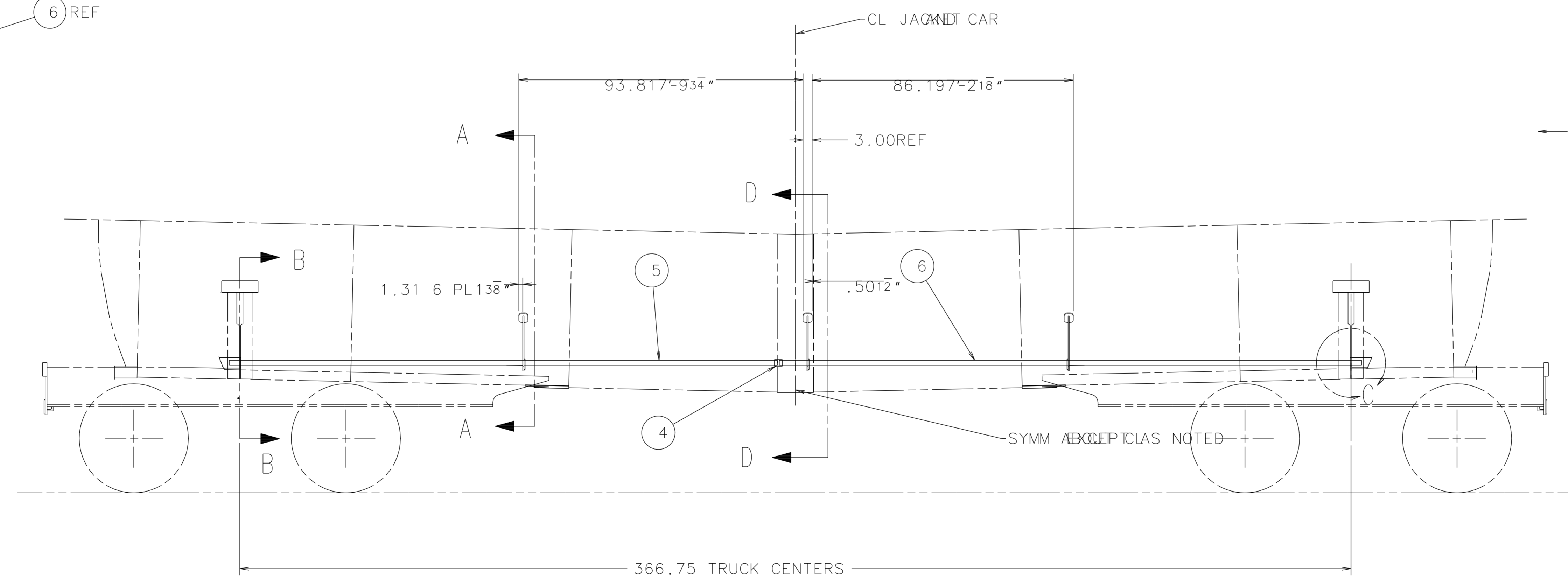

**SECTION B-B**  
SCALE: 1/4

PART NO.: 5U779600

.06